

Collection of Inventory Information - Work Instruction

17/03/2026 9:27 am +10

In this article:

- [Inventory Information Collection](#)
- [Overall Bridge Identification Information](#)
- [Bridge Inventory - General Data](#)
- [Bridge Elements - Surface - Before Bridge](#)
- [Span Information](#)
- [Bridge Elements - Surface - After Bridge](#)
- [Bridge Elements - Outer](#)
- [General Features and Elements](#)

Collection of Inventory Information

Bridge inventory information can be collected at the office or during inspections, which are commonly carried out after construction or reconstruction of a bridge, but can also be done directly before the condition assessment. The main idea of the inventory information is to prepare the background database for the maintenance and rehabilitation planning. **Without correct inventory information it is not possible to carry out the condition assessment.**

The main purpose of it is to obtain inventory data required for network level planning and informed decision making. The inventory information will be collected with standardized series of data items that enable geometry, construction, and function of a bridge to be identified and described.

Inventory Information Collection

The main activity is to collect the relevant information without on-site visit is locating, finding, and reviewing the bridge structure files and plans. The success of this type of inventory inspection is largely dependent on the effort put into documenting of previous design and building process. The data collection activities include reviewing the bridge structure files, plans and documents to identify the main measurements, possible components, and elements. If the data is collected by personnel without proper preparation, the basic components and parameters with terminology is presented to increase the basic knowledge level.

Possible sources of information about the bridge include:

- **The “Design” and “As-built” bridge plans.** The bridge plans contain information about the bridge type, the number of spans, the use of simple or continuous spans, and the materials used to construct the bridge. They also contain information about the presence of composite action between the deck and girders, the use of framing action at the substructure members, and the kind of connection details used. The year of construction and the design loading are also usually contained in the bridge plans.
- **Previous inspection reports** that are done prior to the development of the system. Previous inspection

reports provide valuable information about the history of the bridge, documenting its condition in previous years. This information can be used to determine which components and elements of the bridge warrant special attention. It also allows to compare the current levels of deterioration with those noted during the previous inspections to help determine the rate of deterioration.

- **Maintenance and repair records** that are done prior to the development of the system. Maintenance and repair records allow the inspector to report all subsequent repairs during the inspection phase, noting the types, extent, and dates of the repairs.
- **Rehabilitation/Retrofit plans.** Rehabilitation plans show modifications and replacements performed on the structure. Just as with the design plans, “As-built (or record) drawings are preferable.
- **Geotechnical data** if available. Geotechnical data provides information about the foundation material below the structure. Sand, silt, or clay is more susceptible to settlement and scour problems than is rock. Therefore, structures founded on these materials should generally be given special attention with respect to foundation and scour issues than those founded on rock.
- **Hydrologic data** if available. Hydrologic data provides information about the shape and location of the channel, the presence of protection devices, flood frequencies, and water elevations for various flood intervals. This information is necessary for scour evaluation, expected flood flows, and water velocity.
- **Roadway plans.** Roadway plans may provide some information if the structure plans are not available.

Although the information collection without inspections is a possibility, it is still suggested to check and enter the information during the inventory inspection. Without on-site visits, it is possible to collect inventory information more than ten structures in a day at an average.

The main activity is to collect the relevant information only with inspections defining, counting, measuring, and recording the bridge structure information. The success of this type of inventory inspection is largely dependent on the effort put in the inspections and taking correct photos for post processing in office. During inventory information collection inspection, the main objective is to measure main dimensions (length, width, span length etc.) and define all bridge elements and typologies. Inventory information is the most important part of the database, because without the correct information the system is useless. Based on the collected information, it is possible to distinguish the different types of bridges, present the quantifiable values of structures, and do the initial analysis of bridge network. Inventory information is collected only for bridges and bigger culverts (overall length of over 1.8m).

The data collection can be divided into two separate parts: (1) Dates, location, and measurements, (2) features and elements. The sequence for collecting inventory information is as follows:

1. Search for the bridge in the database (if one exists) or name the bridge after the location (village, road etc.)
2. Define the location or save the bridge GPS location.
3. Measure the main dimensions (Figure 3b. Main transverse dimensions of a bridge. Examples of a few cases of different bridge types)
4. Define the elements (Chapter 4.1.1)

Overall Bridge Identification Information

Region	According to bridge location
Province (Drop down list for Region)	
District (Drop down list for Province)	
Bridge ID code/Number	According to numbering system

Bridge Name	Name of bridge
Inspector's Name	
Date of Inspection	dd/mm/yyyy
Source of information	Field measurements
	Design Drawings/Map/Plan
	As built drawings
	3d Model/Point cloud
	Other - add comment

Bridge Location

The location data (Table 4.2. Bridge location details to be collected) is collected in the same format for all the bridges.

The road section data available in the database should be considered as primary location reference data to be used during the data collection. The referencing data should be verified.

The chainage data should be collected according to Figure 2. If available, GPS coordinates should be added.

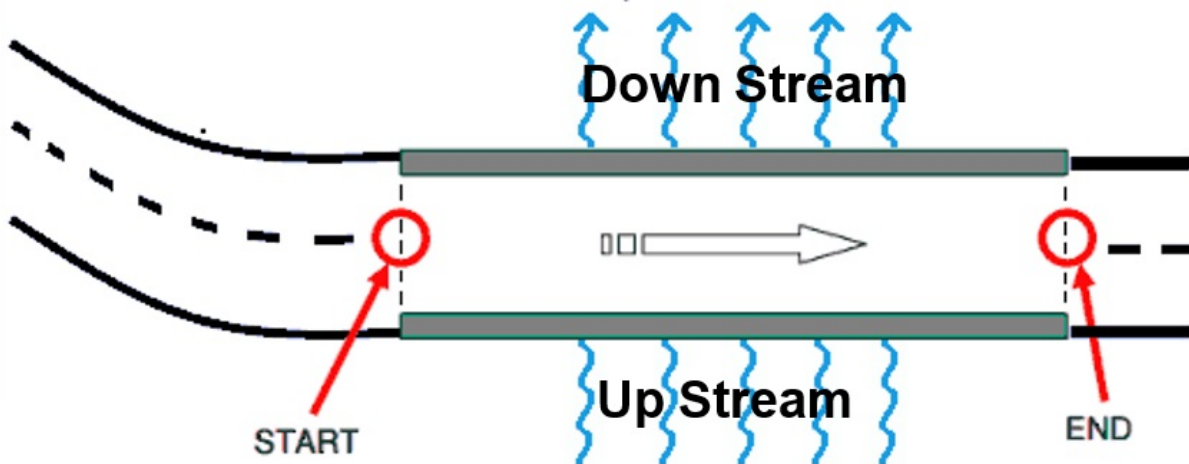

Measurement points of the Chainage (Flow Direction: Upstream to downstream)

BRIDGE LOCATION DETAILS	
Road ID code	The ID of the road on which the bridge is located
Road Name	The name of the road on which the bridge is located
Road address (distance from the road beginning in km)	Distance from the start of road in kilometres
Carriageway (1 or 2)	
GPS coordinates start chainage	
GPS coordinates end chainage	
Feature Crossed	River Name
	Road Number
	Creek
	Minor Creek/stream
	Swamp
	Sea (exposed)

BRIDGE LOCATION DETAILS	
	Estuary (salt water)
	Other (specify)
Detour length for the bridge [km]	Approximate alternative distance of getting to other side of the bridge
Detour time for the bridge [h]	Approximate detour time in hours
Alternative route	Description of the alternative route to other side of the bridge
Construction year	
Rehabilitation year, last	
Rehabilitation type, last	Repair
	Strengthening
	Reconstruction
	Other - add comment

Bridge Geometry

The bridge measurements should be recorded with the resolution of 0.1 m. Preferably on site, but design information can also be a good input. The following Figure 3a and 3b illustrate the main longitudinal and transverse dimensions of a bridge with a few case examples.

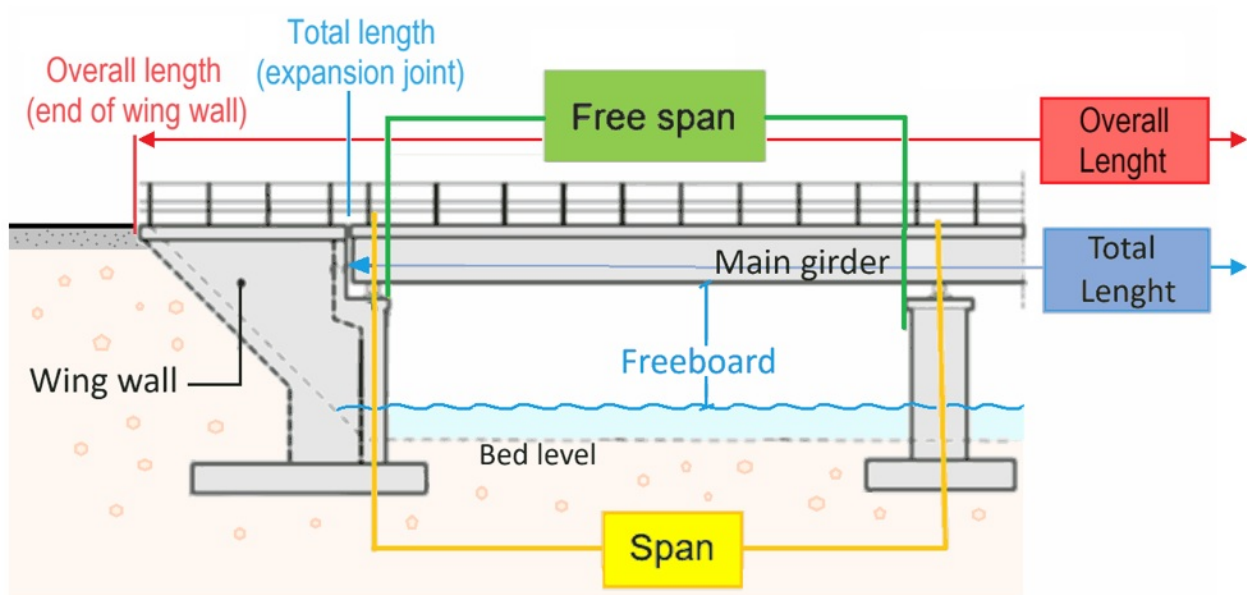

Main longitudinal dimensions of a bridge. The **overall length** is measured from the end of a wingwall to the other side's wingwall's end, while the **total length** is measured without the wingwalls, the distance between the last expansion joints, the expansion joints themselves counted out.

Below are the main transverse dimensions of a bridge, with some examples of a few cases of different bridge types.

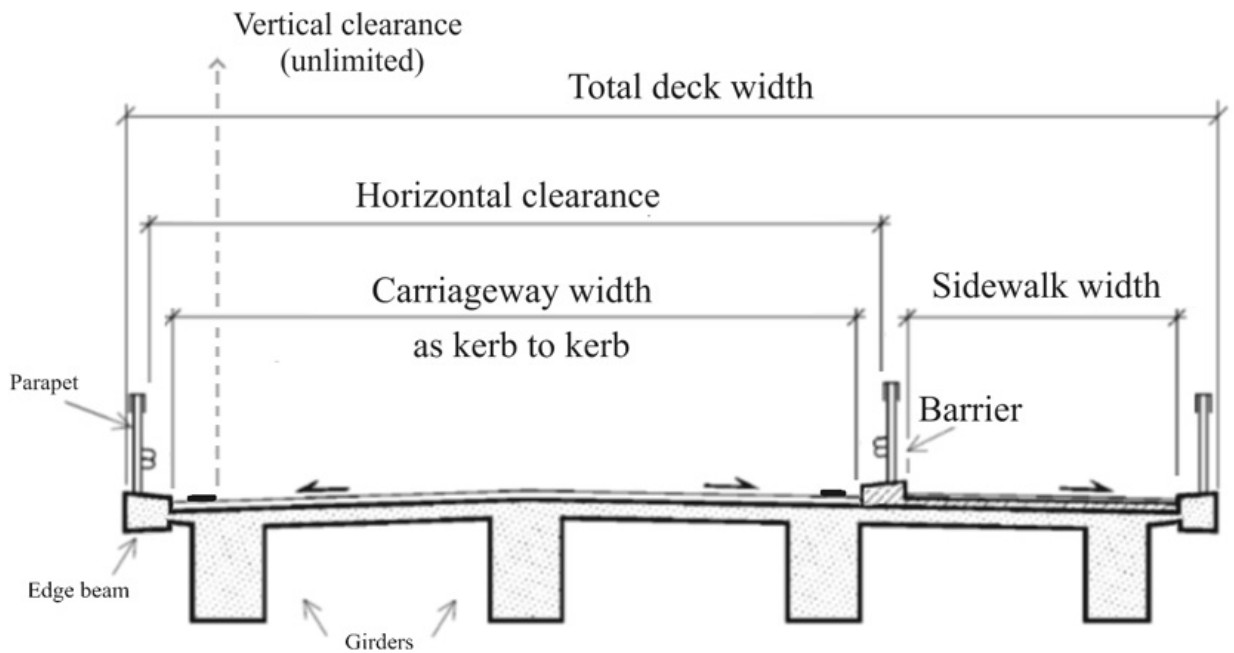

The carriageway width can be considered as kerb to kerb measure, even though sometimes there may be white edge lines marked on the bridge. Sidewalk width is the width of the foot path unless narrowed further by parapets or barriers. Horizontal clearance is the maximum oversize width that can pass the carriageway, in this case from parapet to parapet. Vertical clearance is unlimited.

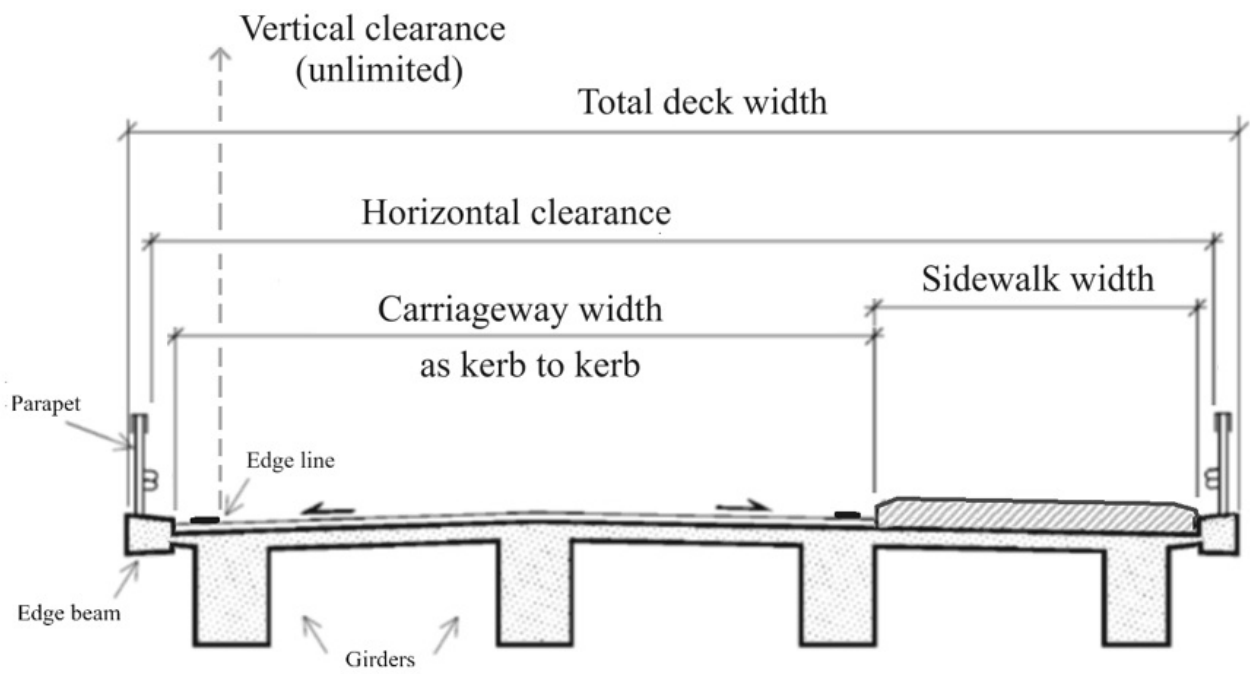

In this case the carriageway width is from the kerb until the kerb or clearly elevated and thus separated sidewalk. In this case the horizontal clearance for oversize transport is from parapet to parapet, spanning over the sidewalk.

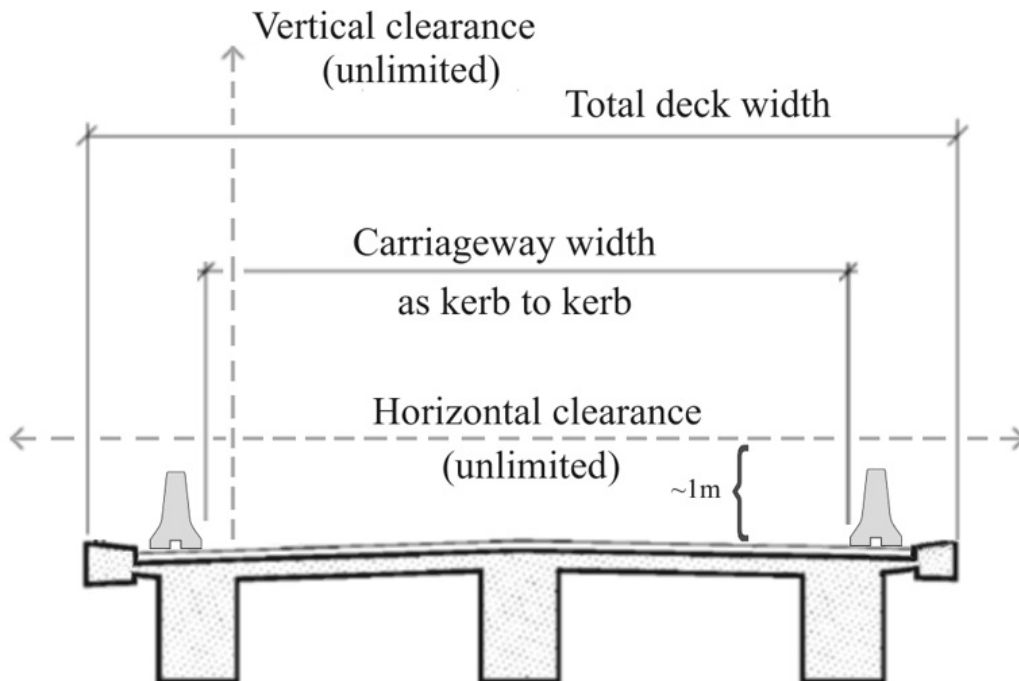

In this case the carriageway is bordered with concrete barriers. However, in addition to unlimited vertical clearance, also the horizontal clearance is considered unlimited for oversize transport as these barriers stay low and there is nothing to block the clearance at over 1m height. Therefore, the bridge does not pose a width limit for an oversize cargo loaded on a trailer or other special equipment transport.

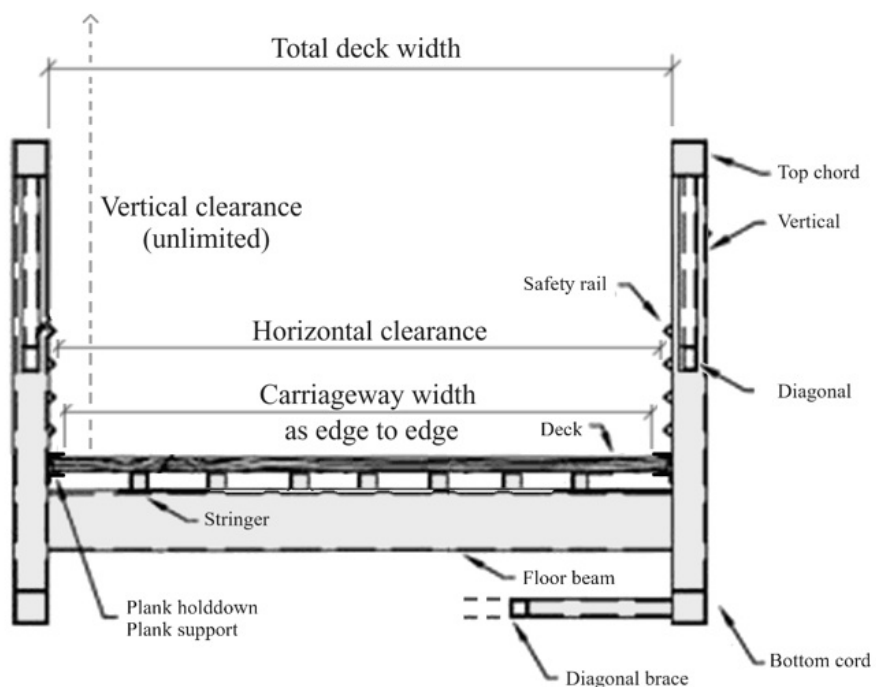

In this example of a half through H-section truss bridge there is no kerbs or dividing parapets, so the carriageway width is measured from the edge of the deck to the other edge.

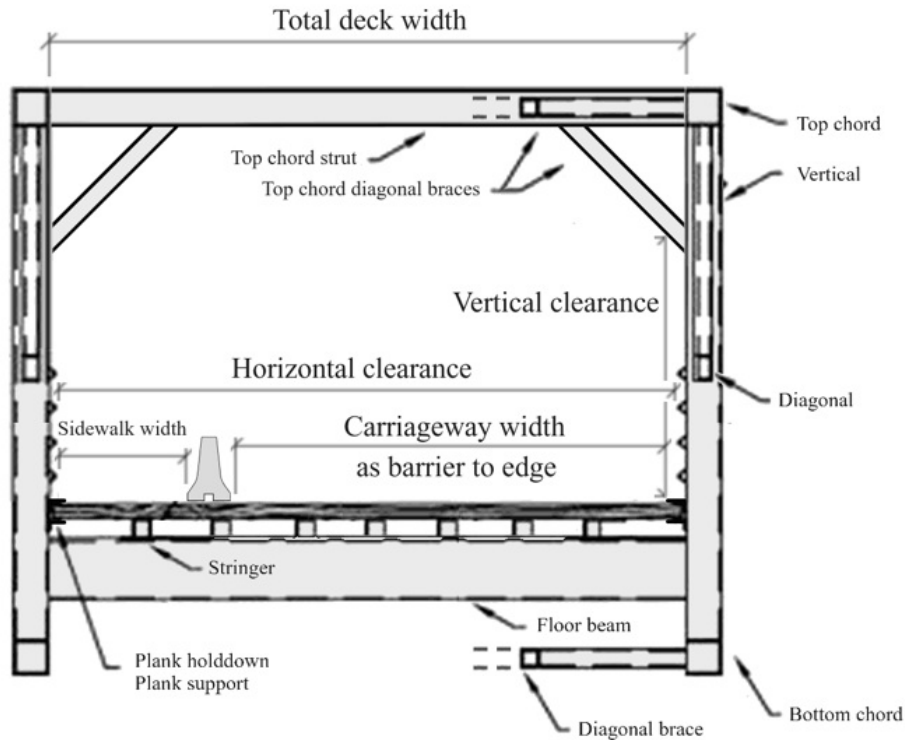

In this example of a full box truss bridge the carriageway width is measured from the kerb/barrier to the edge of the deck. Vertical clearance is not anymore unlimited in this type of a bridge, as it's usually limited by the top chord struts, or even lower because of the diagonal top chord braces as in this example. Note that the clearance is measured at the lowest point over the carriageway. If carriageway is marked then at the lowest point between the edge lines, but if not marked, at the lowest point within the whole carriageway. Horizontal clearance is between the parapets, spanning over the divider, as the concrete barrier is less than 1m high.

Bridge Inventory - General Data

Type of crossing	Bridge
	Viaduct
	Light traffic bridge
	Underpass
	Culvert
	Ford
	Special - add comment
	Other - add comment
	Other - add comment
Principal feature (traffic above)	Car traffic
	Pedestrian/light traffic
	Wildlife
	Other - add comment
	Box culvert cell
	Brick (Arch)
	Cantilever and suspended span
	Concrete pipe culvert
	Continuous

Structural (Span) Form of the Bridge	Corrugated steel culvert
	Integral
	Partially continuous
	Rigid-frame/Fixed end
	Simply supported
	Tubular
	Other – add comment
Skew angle	
Number of car lanes on bridge	
Clearances on road carried (Principal Feature) [m]	1. Vertical Clearance – height between the top of the deck to the underside of any transverse element. No limits leave blank.
	2. Horizontal Clearance – distance between the inside faces of the outer elements (truss or parapet). No limits leave blank.
Overall Length [m]	Distance between the furthestmost elements of a bridge
Total Deck Length [m]	Along the direction of the road, the distance between the outer edges of the abutment expansion joints.
Total deck width [m]	Distance between outermost edges of deck
Sidewalk width Left [m]	Total sidewalk/walkway width on the left
Sidewalk width Right [m]	Total sidewalk/walkway width on the right
Carriageway width [m]	Kerb to kerb width

*Skew angle can be determined using the Compass feature on the Tripltek tablet (Outdoors folder): Angle (acute or obtuse) subtended by Route Direction & Normal to the Flow Direction.

Bridge Elements - Surface - Before Bridge

Approach way (cover) material	Asphalt concrete
	Surface dressing
	Concrete
	Earth
	Gravel
Approach way (Side)	Kerbs
	Safety barrier
	Drainage gully
Approach way Material - Kerbs	Concrete (on site)
	Concrete (Precast)
	Masonry
	Aluminium fixed
	Aluminium flexible
	Concrete
	Concrete & steel
	Steel

Approach way Material – Safety barrier	Timber (Normal)
Approach way Material – Drainage gully	Concrete (on site)
	Concrete (Precast)
	Masonry
	Steel
	Plastic
Approach way width [m]	Width of the road structure or kerb to kerb
Overlay/Deck wearing surface (Road)	Asphalt concrete
	Surface dressing
	Concrete
	Steel plates/Grating
	Timber planks
	Bitumen
Overlay/Deck wearing surface (Sidewalk)	Asphalt concrete
	Surface dressing
	Concrete
	Steel plates/Grating
	Timber planks
	Bitumen
Signs (Bridge Sign)	Yes/No
Signs (Reflectors)	Yes/No
Parapet	Yes/No

Span Information

(Note that information inserted for Span 1 continues throughout the spans unless it is unique for a span and is changed during the inspection – span length normally on multi-span bridges).

Span 1 - Contains Near Abutment Data

Number of Spans	
Span Length (m)	The span length should be defined for every span
	Buried
	Steel – prefabricated
	Nosing
	Compression seal

Expansion Joints	Rubber Extrusion
	Steel finger
	Sliding plate
	Reinforced elastomeric
	Elastomeric in metal runners
	Elastomeric strip seal
	Elastomeric box seal/Modular
	Cantilever Comb and Tooth
	Steel angle
	Other – add comment
	None
	Abutment height
Exposed height of the abutment [m]	
Longitudinal width of the abutment [m]	
Abutments	Gravity
	Pile (stub abutment)
	Bank-seated (stub abutment)
	Wall and counterfort
	Spill through abutment
	Full height integral
	Integral with pile foundation
	Integral with spread footing
	Gabions
	Reinforced earth abutment
Abutment cap	Concrete (on site)
	Concrete (Precast)
	Timber (Normal)
	Steel
Bearings	Lubricated steel plates
	Neoprene rubber sheet
	Pot-cum-PTFE slided-guided/free
	Pot-cum-PTFE fixed
	Single roller
	Roller nest
	Segmental rocker
	Segmental rocker nest
	Rocker
	Pinned rocker
	Plain neoprene pads
	Laminated neoprene pads
	Isolation
	Friction pendulum
	High dampening rubber
	Spherical pot
	Disc bearing
	Pin and link
Unknown	

	None
Wing walls are part of abutment	Yes/No
Wing walls	Free standing
	Strengthened/Reinforced
	Splayed
Wing walls material (Free Standing & Splayed)	Concrete (on site)
	Concrete (Precast)
	Timber (Normal)
	Masonry
Wing walls material (Strengthened/Reinforced)	Soil
	Gabions
	Masonry
Reinforced earth wall	With relief culvert
	Without relief culvert
Reinforced earth wall materials	Concrete (Precast)
	Geostrip
Barriers	Vehicle restraint system
	Hand rails
	Structural element
Barriers material	Steel
	Concrete
	Concrete and steel
	Timber
Deck	Solid slab
	Voided slab
	Truss
	Log
	Unknown
Deck material – Solid slab & Voided slab & Deck edge beam	Concrete (on site)
	Concrete (Precast)
	Concrete (Pre-tensioned)
	Concrete (Post-tensioned)
	Timber (Normal)
	Timber (Tensioned)
Deck material - Truss	Steel
	Timber (Normal)
Deck material - Log	Timber (Normal)
Deck (edge beam)	Concrete (on site)
	Concrete (Precast)
	Concrete (Pre-tensioned)
	Concrete (Post-tensioned)
	Timber (Normal)
	Timber (Tensioned)
	Bailey
	Box Girder
	Girder
	Deck truss

Main Girder	Through truss
	Log
	Slab
	Arch
	Culvert
Main Girder Material - Bailey	Frame
	Standard
	Super
	Compact 100
	Compact 200
Main Girder Material - Box Girder & Girder	Universal
	Other
	Concrete (on site)
	Concrete (Precast)
	Concrete (Segmental)
Main Girder Material - Deck truss & Through truss	Concrete (Post-tensioned)
	Steel
	Timber (Tensioned)
	Steel
	Timber (Normal)
Main Girder Material - Log	Timber (Normal)
	Timber (Normal)
Main Girder Material - Slab	Concrete (on site)
	Concrete (Precast)
	Concrete (Pre-tensioned)
	Concrete (Post-tensioned)
	Timber (Normal)
	Timber (Tensioned)
Main Girder Material - Arch	Steel
	Masonry
	Concrete (on site)
	Concrete (Precast)
	Concrete (Pre-tensioned)
	Concrete (Post-tensioned)
Main Girder Material - Culvert	Steel
	Composite (steel + soil)
	Concrete (on site)
	Concrete (Precast)
	Plastic
Main Girder Material - Frame	Concrete (Pre-tensioned)
	Concrete (Post-tensioned)
	Steel
	Concrete (on site)
	Concrete (Precast)
	Girder
	Beam (diaphragm)

Secondary member	Bracing
	Cable
	Log
Secondary member Material – Girder & Beam (Diaphragm)	Concrete (on site)
	Concrete (Precast)
	Steel
Secondary member Material - Bracing	Steel
	Timber (Normal)
Secondary member Material - Cable	Steel
Secondary member Material - Log	Timber (Normal)
	Timber (tensioned)
Other member	Vertical restraint system
	Seismic dampers
Drainage	Outlet pipes
	Downspout pipes
	Deck drains
	Pipe
Drainage Material - Outlet pipes & Downspout pipes	Steel
	Stainless Steel
	Plastic
Drainage Material – Deck drains & Pipe	Concrete (on site)
	Concrete (Precast)
	Steel
	Plastic
Construction joints/Hinges	Steel
	None

For Multi-span bridges with 'N' spans - Spans 2 to Span (N-1)

As per previous table but with Abutment data removed and the following Pier data added:

Piers	Solid wall
	Multiple column
	Single column
	Gravity
	Trestle column with bracing
	Pile
	Cantilever
	Integral
Piers material – Solid wall, Multiple column, Single column	Concrete (on site)
	Concrete (Precast)
	Composite (steel & Concrete)
	Composite (masonry & concrete)
	Timber (Normal)
	Steel
Piers material - Gravity	Masonry
	Concrete (on site)
	Steel

Piers material - Trestle column with bracing	Masonry
	Composite (masonry & concrete)
Piers material - Pile	Concrete (on site)
	Concrete (Precast)
	Composite (steel & Concrete)
	Composite (masonry & concrete)
	Timber (Normal)
	Steel
Piers material – Cantilever, Integral	Concrete (on site)
	Steel
	Composite (steel & Concrete)
Pier Cap	Concrete (on site)
	Concrete (Precast)
	Timber (Normal)
	Steel
Clearances underneath [m] Vertical Clearance /Measured freeboard	
Clearances underneath [m] Horizontal Clearance (free span)	
Bearings 1 & 2 (each pier can have 2 sets of bearings which may be different types) For continuous decks over the pier with only 1 bearing, Bearing 2 shall be “None”	Lubricated steel plates
	Neoprene rubber sheet
	Pot-cum-PTFE slided-guided/free
	Pot-cum-PTFE fixed
	Single roller
	Roller nest
	Segmental roller
	Segmental rocker
	Segmental rocker nest
	Rocker
	Pinner rocker
	Plain neoprene pads
	Laminated neoprene pads
	Isolation
	Friction pendulum
	High dampening rubber
	Spherical pot
	Disc bearing
Pin and link	
Unknown	
None	
Bearing movement indicator	Yes/No

End Span 'N'

As per **Span 1** table (with far Abutment data) with the Pier Elements from previous table added.

Bridge Elements - Surface - After Bridge

As per **Bridge Elements - Surface - Before Bridge** table.

Bridge Elements - Outer

Riverbed protection	None
	Riprap
	Gabions/Reno mattress
	Concrete
	Filter point mattress
	Articulated block mattress
	Not known
Training	None
	Sheet piled wall
	Gabion groins
	Timber groins
	Filter point mattress
	Articulated block mattress
	Embankment and gabions
	Embankment and riprap
Scour protection	None
	Sheet piled wall
	Gabion groins
	Timber groins
	Filter point mattress
	Articulated block mattress
	Riprap
	Gabions/Reno mattress
	Not known
Spread footings	Concrete
Piles	Concrete
	Steel/Concrete (Circular)
Caissons	Steel (Circular)
	Steel (H section)
	Concrete (bored cast in situ under rugged)
	Concrete (driven precast)
	Concrete (precast and prestressed)

General Features and Elements

The Bridge Inspector ought to be familiar with the components and elements of the bridge to be inspected ahead of arriving at the site. To provide a reasonable level of confidence in the safety of the bridge, knowledge of the structure and good engineering judgment by the inspector is necessary. The relevant Templates for element information input is presented in Annexes C, D and E. Examples of most common Bridge Construction Types are presented next.

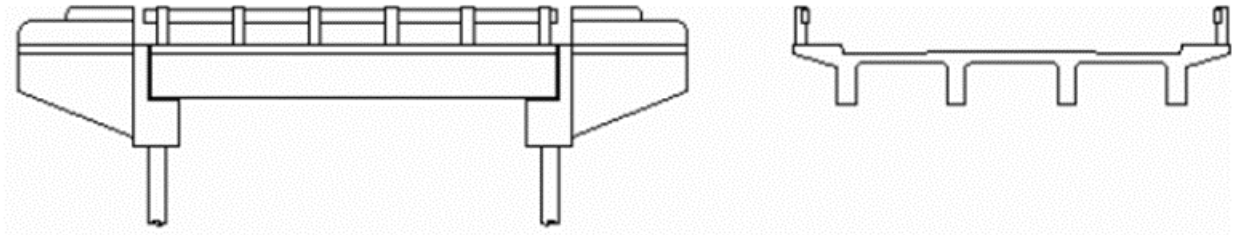

Girder Bridge

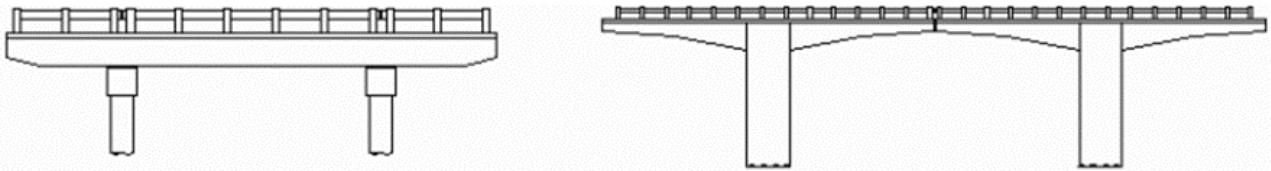

Cantilever bridge

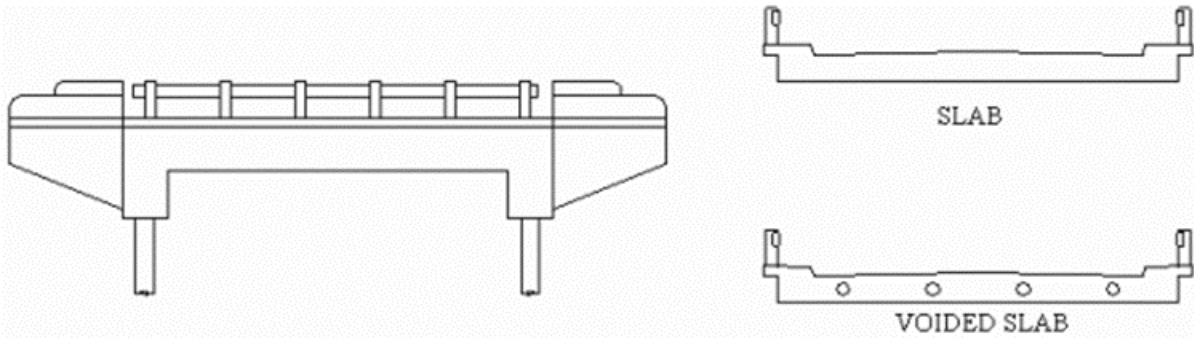

Slab bridge

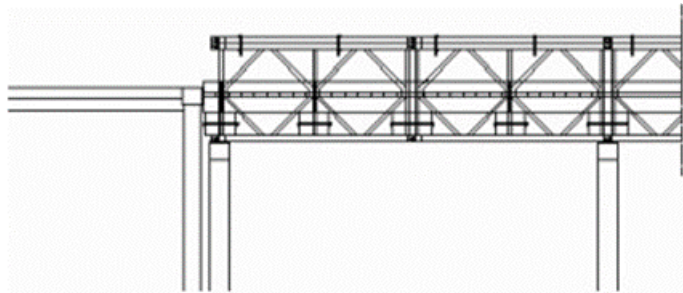

Bailey bridge

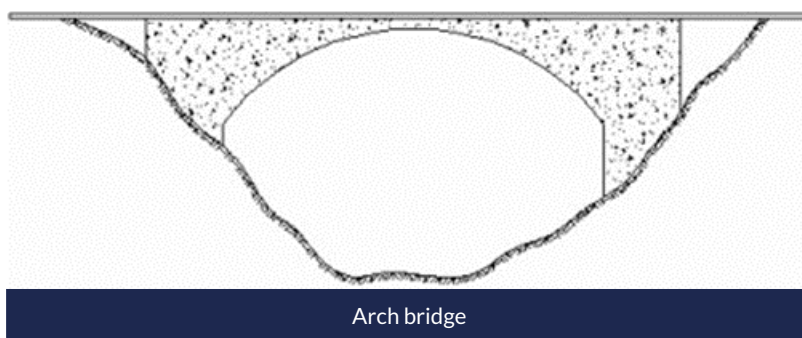
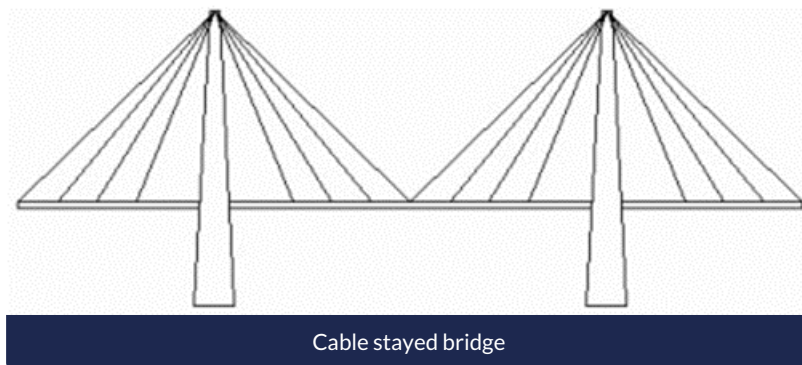
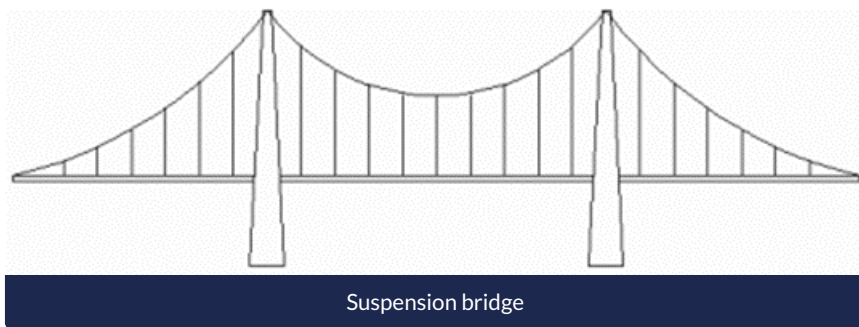
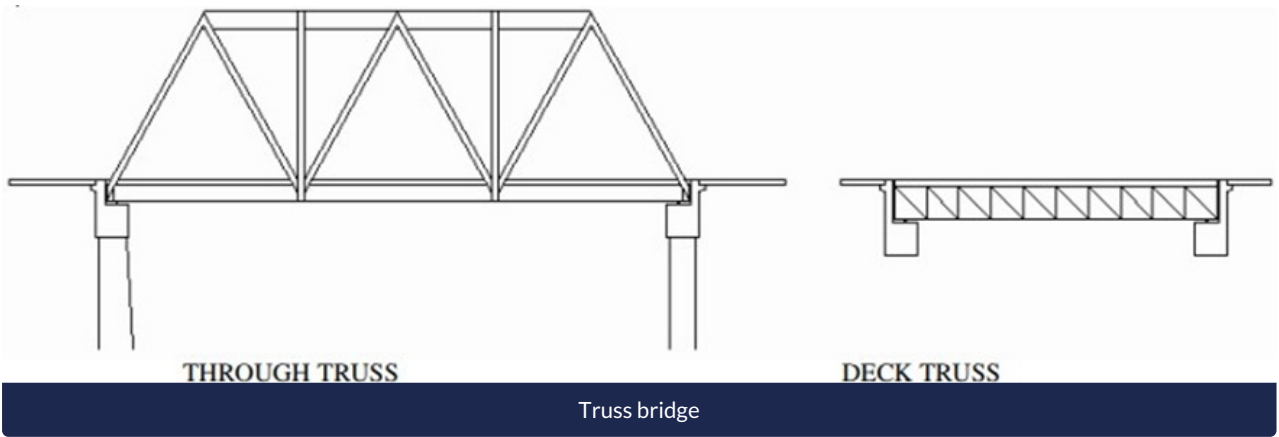

The Bridge Inspector should be acquainted with the main components of the bridge. The overall position of elements is presented below.

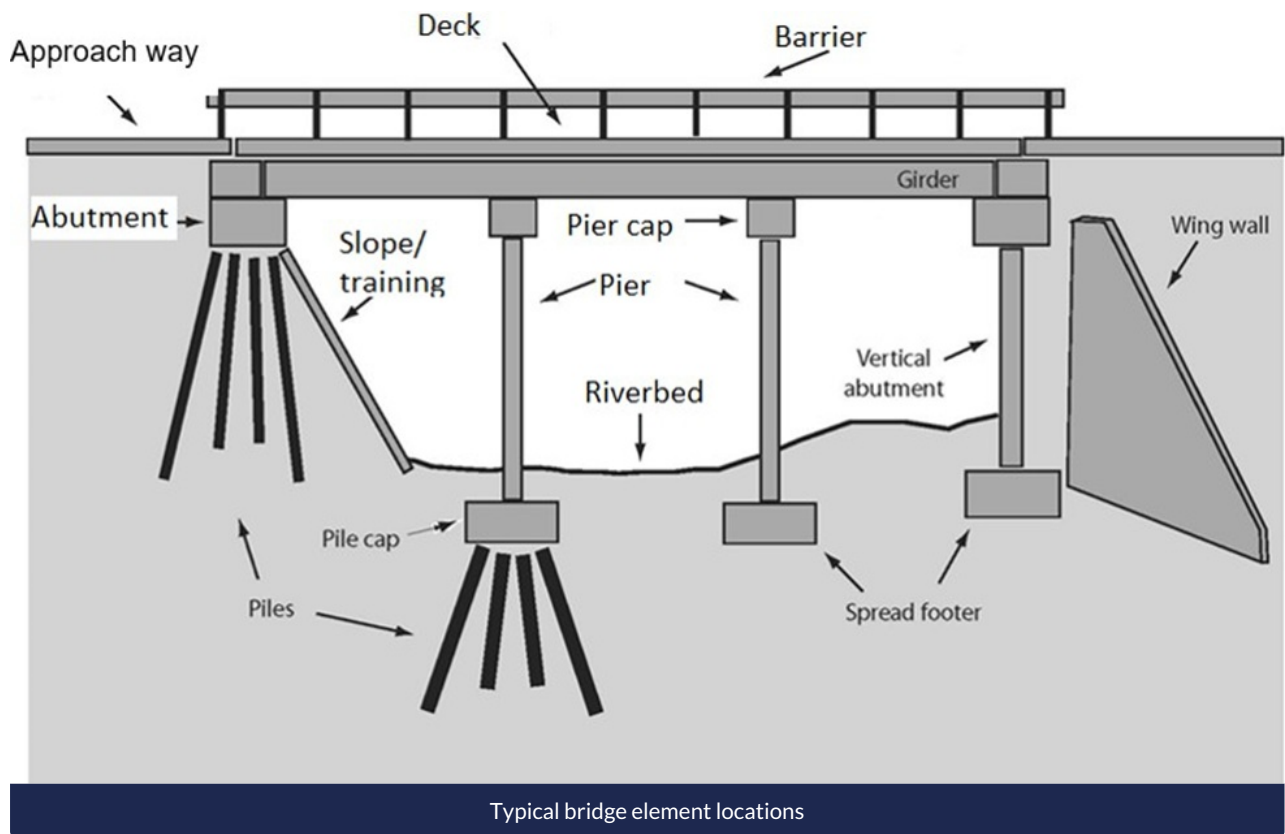

Elements

Surface

- Approach way (cover) 10 metres of roadway before and after the structure.
- Approach way (side) 10 metres of roadway sides before and after the structure.



- Overlay/Deck wearing surface – top layer of the bridge, mainly influenced by the traffic.
- Barrier and handrails – safety elements on the sides of a structure.



- Signs - related to traffic management, typically sign with a bridge name.
- Parapet

Superstructure

- Deck - load-bearing element that distributes the traffic load from top-layer to girders.
- Edge beam - side of a bridge deck that protects main girders from water and other pollutants.
- Expansion joints - connection points of a road and a bridge or different spans of a bridge. Allows the structure to deform longitudinally without causing additional stresses.
- Main girder - main load-bearing element
- Secondary member - load bearing element for secondary or perpendicular forces

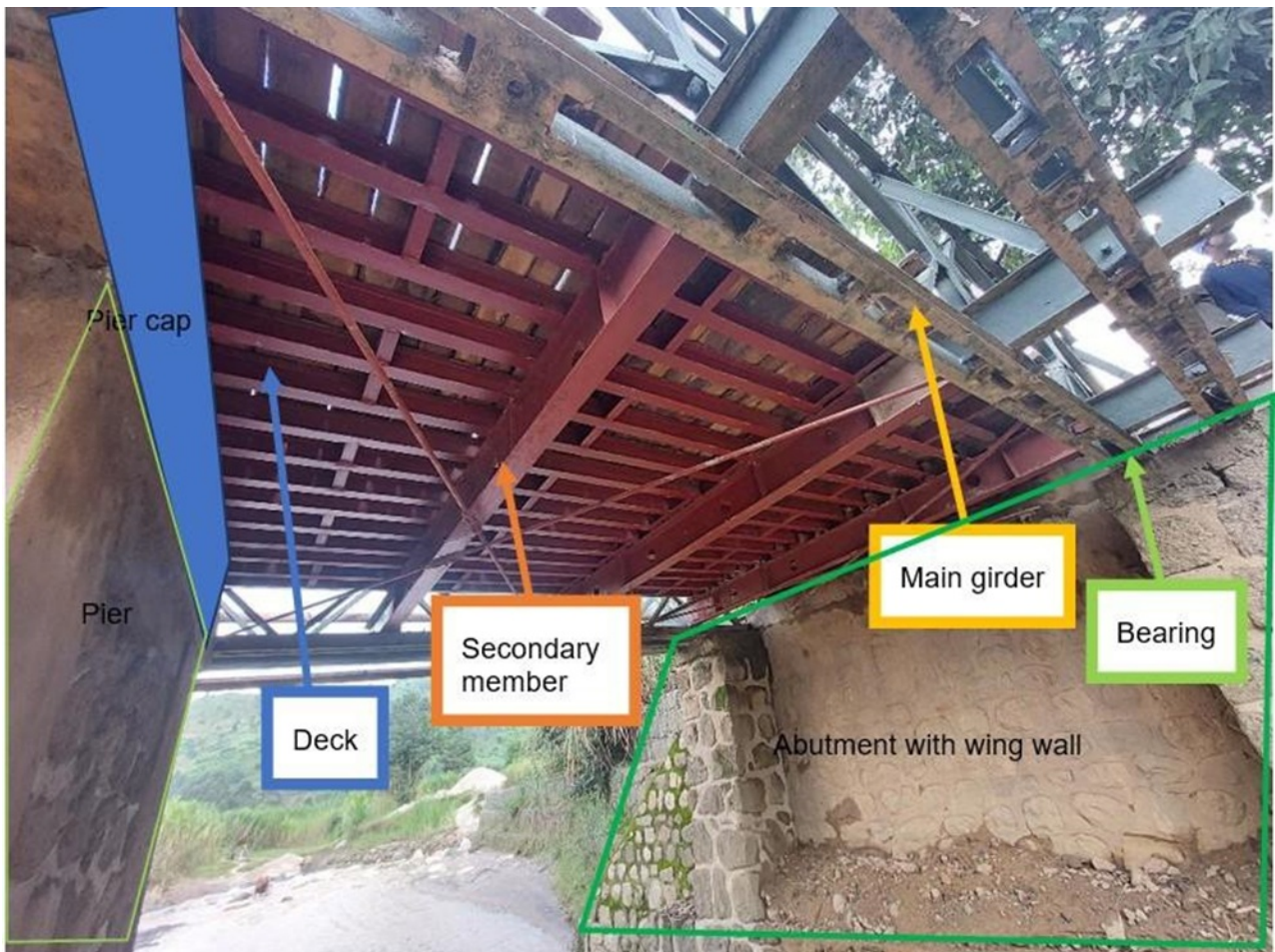

- Other member

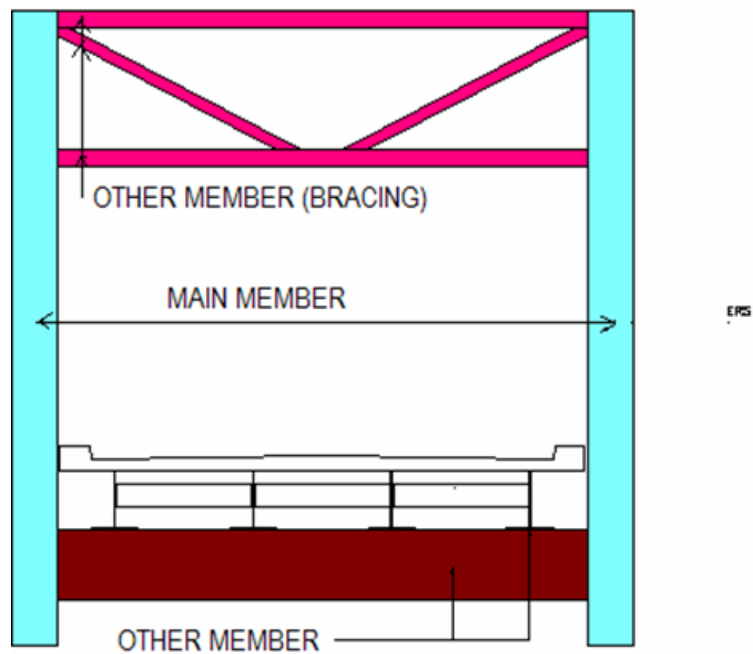

Substructure

- Bearings (Select TWO times) – connection between super- and substructure. Allows superstructure to move without causing additional stresses

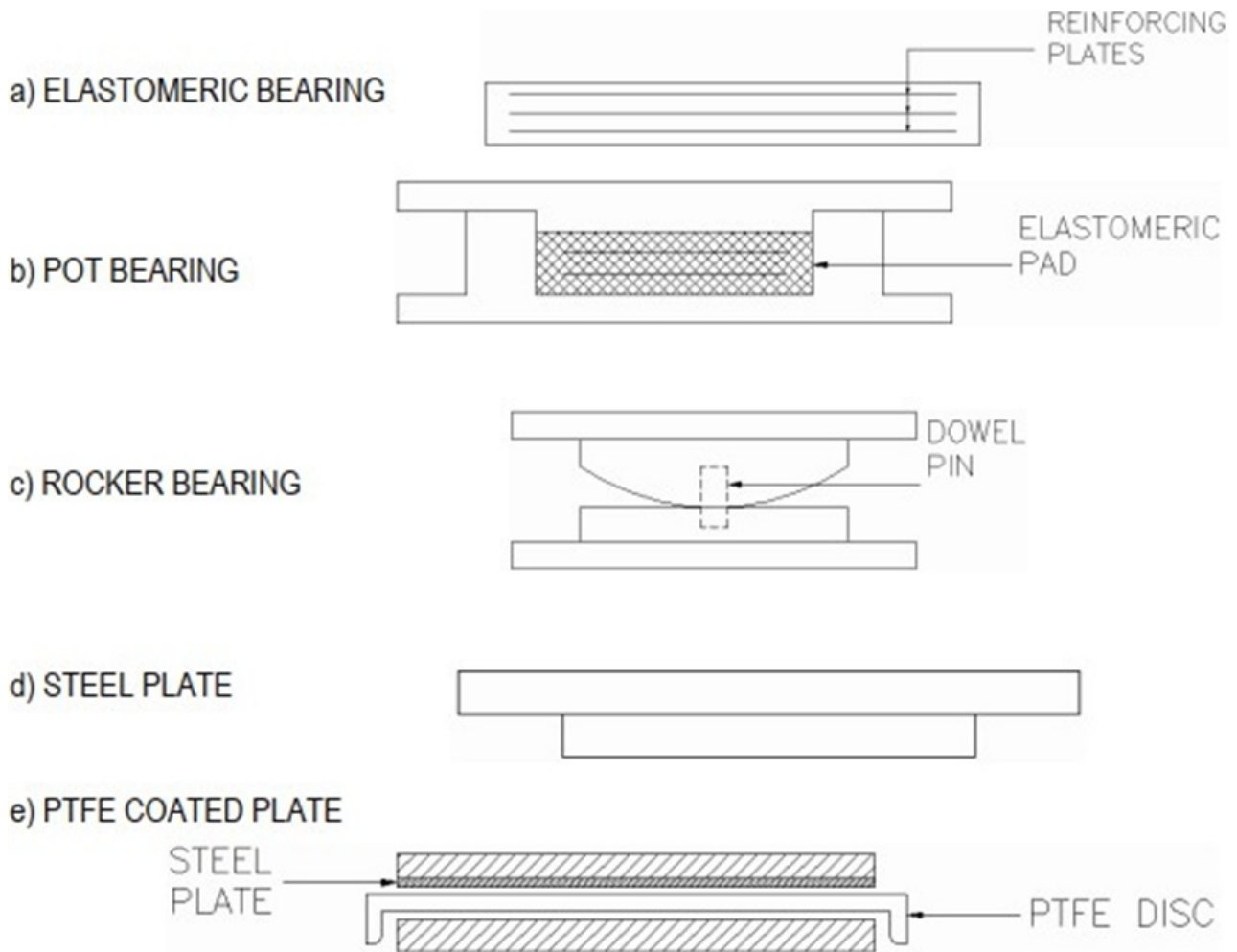

- Bearing movement indicator
- Drainage – water management elements
- Construction joints/Hinges – special elements of longer structures or structurally designed, keeping the stresses in a safe zone.
- Abutments – load bearing elements of substructure
- Wing walls – keeping the soil of a roadway in place to prevent settlements.
- Piers – load-bearing elements of a substructure located in the middle of a structure.
- Pier Cap – top of the pier, mostly made to transfer the forces from superstructure to substructure.
- Abutment Cap

Other

- Foundation – bottom load-bearing element of a structure. Mainly located in the soil and not visible
- Riverbed protection
- Slope training
- Scour protection